

# ARHS 60X-L

60cm Slide-out Rangehood



## FEATURES & BENEFITS



### 440m<sup>3</sup>/h Extraction

Removes cooking odours with ease



### 50.6dB Noise Rating

Quiet operation makes this unit perfect for open plan kitchens.



### LED Lighting

Giving extra light when needed in the kitchen.



### 2 Speed Settings

Depending on what you're cooking you can vary the amount of extraction as required.



**5 YEAR WARRANTY** on parts and labour.

## TECHNICAL SPECIFICATIONS

Construction Type/Product Family	Slide-out rangehood
Speed settings	2
Lighting type	LED/Rear set
Control Type	Button Control
Colour	Stainless steel
Filter Type	Aluminium Filter
Motor	Dual
dB Rating	50.6dB
Ducting diameter	120mm
Location & Length of Power Cable	
Electrical Connect Requirements	200W
Voltage (V)	220/240V
Frequency (Hz)	
Approval Certificates	CE

## DIMENSIONS

Product Dimensions (W) x (H) x (D)	600 x 176 x 280
Package Dimensions (W) x (H) x (D)	
Weight	8kg

## ACCESSORIES INCLUDED

Ducted rail height	40mm
Recirculating rail height	80mm

# ARHS 60X-L

60cm Slide-out Rangehood



## Product dimensions

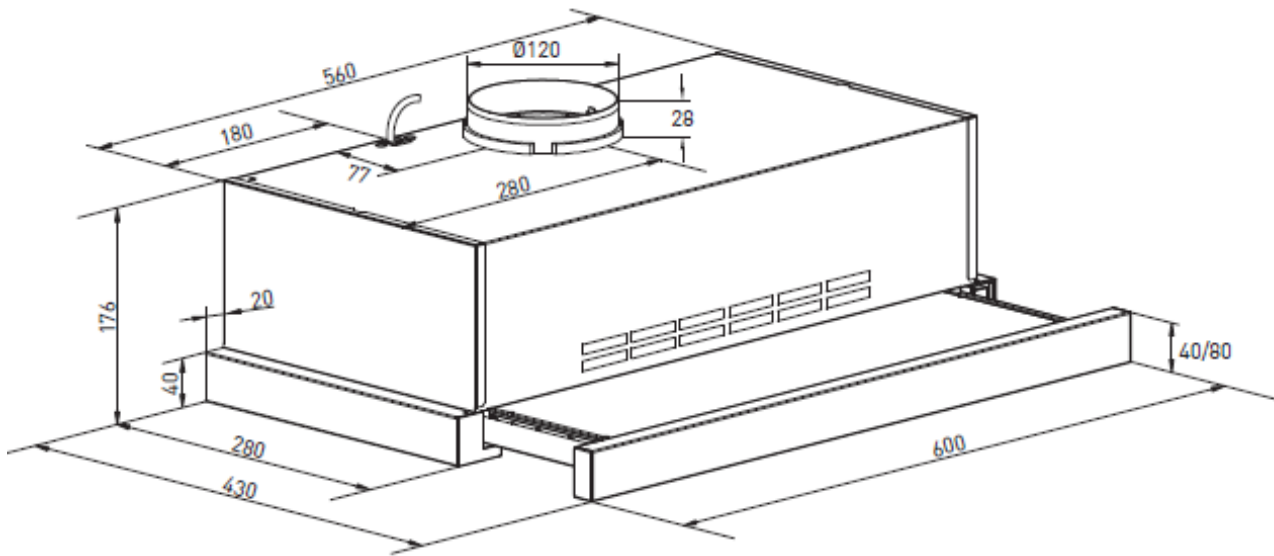

## Rangehood/cooktop clearance

**WARNING:** technical specifications and product sizes can be varied by the manufacturer, without notice. Cut outs for appliances should only be by physical product measurements. The above is indicative only.

DISTRIBUTED BY ARISIT PTY LTD  
40-50 Mark Anthony Drive,  
Dandenong South VIC 3175  
Ph: 1300 762 219  
Fax: 03 9768 0838  
Website: [www.arisit.com](http://www.arisit.com)

1A Howe Street,  
Newton, Auckland NZ 1145  
Ph: (09) 306 1020  
Website: [www.arisit.com](http://www.arisit.com)